

ATOMIK 215 PEL

Valigia porta utensili in polipropilene ad alto spessore



Caratteristiche generali

- 2 braccetti reggi coperchio in metallo
- 2 serrature con chiave
- 3 cerniere posteriori in metallo
- fondo con divisori rimovibili e regolabili
- maniglia ergonomica rivestita in gomma
- targhetta portanome
- area porta documenti
- predisposizione per terzo pannello aggiuntivo

Caratteristiche

- 2 pannelli porta utensili con elastici su un lato

Versioni

- ATOMIK /R PEL
- ATOMIK /R WH PEL
- ATOMIK 215 PEL
- ATOMIK 215 PSS
- ATOMIK 215 PTS
- ATOMIK TWIN PTS
- ATOMIK WH PEL
- ATOMIK WH PSS
- ATOMIK WH PTS

EAN

8024482015668



Specifiche tecniche	A	B	C	D	E
mm dimensioni interne	465	352	215	95	120
Peso Kg 4,70					
inc dimensioni interne	18 5/16	13 7/8	8 7/16	3 3/4	4 3/4
Peso lbs 10.36					

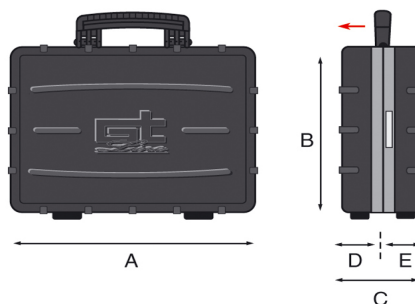

ATOMIK 215 PEL

Valigia porta utensili in polipropilene ad alto spessore



Valigia in polipropilene ad alto spessore, stampata ad iniezione. Grande resistenza alle sostanze corrosive, agli urti e alle alte e basse temperature. La tecnica ad iniezione consente di ottenere uno spessore costante del materiale delle calotte, soprattutto negli angoli.

Accessori

ATOMIK 215 PEL



UNIVERS.TROLLEY



WL01



WL02



WL03



WL04



WL05



LOCK BELT



PAN ATOMIK



FOAM ATOMIK